

Grid Tie Solar Inverter

EnerSolis series 2K/3K/4K/5K

User's Manual

Contents

1	Foreword.....	2
2	IMPORTANT SAFETY INSTRUCTIONS	3
3	OVER REVIEW	5
	3.1 External dimensions	5
	3.2 Unit Description	6
4	Installation.....	7
	4.1 Unpacking.....	7
	4.2 Installation Requirements	8
	4.3 Mounting the unit	10
	4.4 Electrical installation	12
5	Front panel Functional Descriptions	17
6	Starting the inverter.....	19
	6.1 Operation Test and Installation Instruction.....	19
	6.2 Check Measured Values & Figures detected by INVERTER.....	21
	6.3 Inverter status descriptions.....	25
7	The communications interface.....	26
	7.1 Standard communications interface.....	26
	7.2 Option communication card	27
8	Inverter Status diagnostics and repair.....	32
9	Specifications.....	35

1 Foreword

Thank you for buying this inverter. Many years of experience in the design of power device have gone into construction of this device. We hope that this device will also give your solar system many years of trouble-free operation. However, it should be mentioned that an inverter is a complex electronic system which is also confronted with a wide variety of local conditions. If questions arise or a malfunction occurs, do not hesitate to call your specialized dealer. He or she will try to help you as quickly and straightforwardly as possible.

Please read this user's guide carefully to familiarize yourself with the device. Remember to pay special attention to the information on installing and commissioning the device.

2 IMPORTANT SAFETY INSTRUCTIONS

General



Warning! Incorrect operation and work performed incorrectly can cause serious injury & damage! Only qualified staff are authorized to install your Enersolis and only within the scope of the respective technical regulations. Do not start operation or carry out maintenance work before you have read the chapter "Safety Regulations"!

- **This manual contains important instructions for the Enersolis 2200, 3300, 4200, 5000 that shall be followed during installation and maintenance of the inverters.**



Warning! These servicing instructions are for use by qualified personnel only. To reduce the risk of electric shock, do not perform any servicing other than that specified in the operating instructions unless you are qualified to do so.

Housing

- **Only qualified installers are authorized to open the connection area. Do not open the connection area when the inverter is in under-voltage condition.**
- **Only well-trained service staff may open the upper portion (power stage) of the inverter, and only when it is not in under-voltage condition.**

Repair

Only well-trained service staff is authorized to carry out repairs to the Enersolis unit.

PV module

Before connecting the solar modules, you must check whether the voltage parameters specified in the manufacturer's data correspond with the actual parameters. When checking the voltage reading, please take into account that solar modules supply a higher no-load voltage when temperature is low and sunlight level remains unchanged. At 14 °F (-10 °C) the open-circuit voltage of the PV modules must never exceed 500 V. The data sheet of the solar module will tell you the temperature factors applicable for ascertaining the theoretical open-circuit voltage at 14 °F (-10 °C). If the solar modules exceed an open-circuit voltage of 500 V, the Enersolis might be damaged and all warranty right will be voided.

The Enersolis includes a Residual current monitoring unit (RCMU) according to UL1741. This device measures the ground current of the PV array and prevents the inverter from feeding the grid in case of a ground fault.

Grid connection

Only appropriately licensed contractors are authorized to connect the Enersolis to the grid. Consult your local authorities for specific requirements. Before connecting the Enersolis to the grid, permission for the connection must be granted by the utility company.

3 OVER REVIEW

3.1 External dimensions

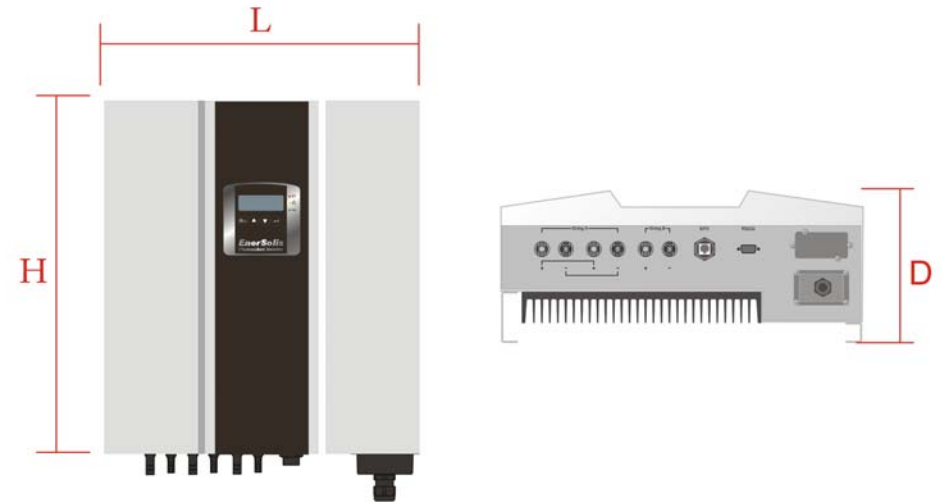

Front view

Bottom view

Module number	ES 2200/3300	ES 4200/5000
Dimensions(mm)		
L	455	455
H	430	510
D	170	170

3.2 Unit Description

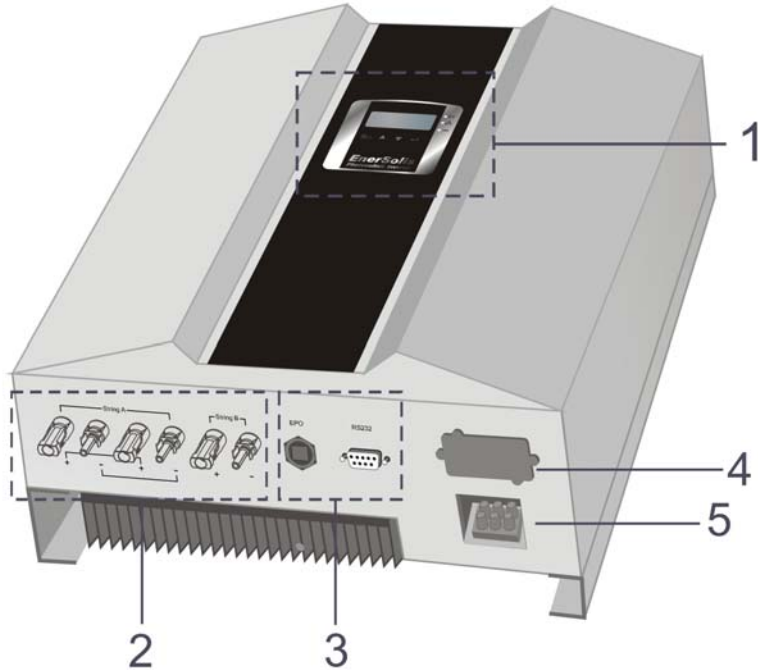

1. LCD & LED Display: Showing the operation information and status of the inverter.
2. Solar array input: Plug-and-play connectors the for connection of the solar modules (The Enersolis 2200/3300 only have one PV string input).
3. Standard communication Port : EPO & RS232.
4. Optional communication slot: USB, RS485, Dry contact, TCP/IP.
5. AC output terminal: AC output for the utility supply.

4 Installation

Read the Safety Instruction guide (page 3 to 4) before installing the PV INVERTER.

4.1 Unpacking

Inspect the PV INVERTER upon receipt. The manufacturer designed robust packaging for your product. However, accidents and damage may occur during shipment. Notify the forwarder and dealer if there is damage.

The packaging is recyclable; save it for re-use or dispose of it properly.

Remove the INVERTER from the carton box.

Check the package contents. Standard content shall include :

- ✓ 1 set of accessories
- ✓ 1 set of data CD-ROM
- ✓ 1 set of mounting frame Accessories Kit as below:

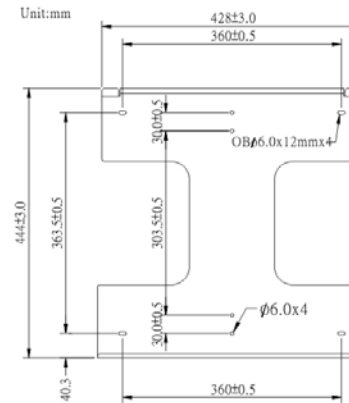

ES4200/5000

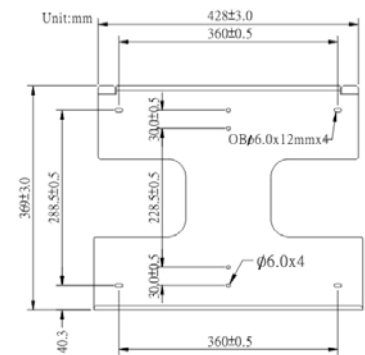

ES2200/3200

4.2 Installation Requirements

The Enersolis is heavy. Take this weight into account when choosing the installation site and method of installation.

To ensure proper operation and long operating life, always position the Inverter according to the following requirement :

(1)The Enersolis is designed for outdoor installation and should be installed in a place where it is not exposed to direct sunlight. The yield of the PV system may reduce at increased ambient temperatures or when installed in poorly ventilated and warm indoor locations. We advise the ambient temperature inside the -25°C to $+50^{\circ}\text{C}$ range.

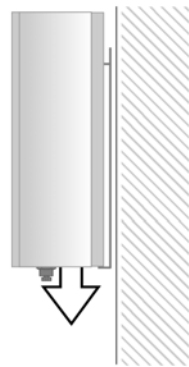
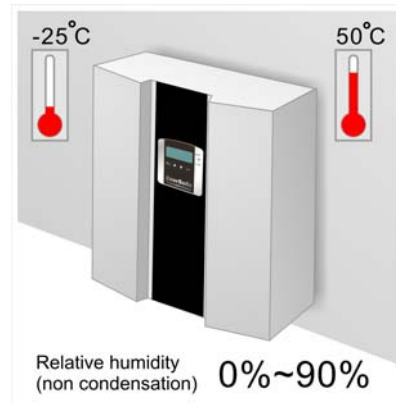

ES2200/3200 27Kg
ES4200/5000 29Kg

(2) The Enersolis is designed to be mounted on a vertical wall. If installing the unit outdoors, make sure that it is not slanting forward.

We advise against installing the unit in a horizontal position outdoors.

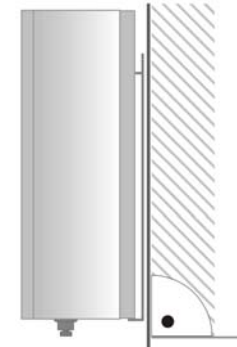

Install the inverter vertically or tilting backward.

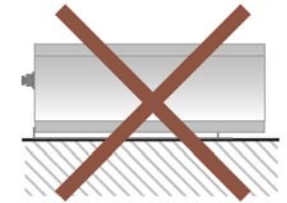
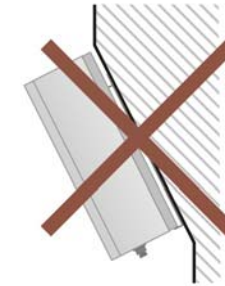

Never install the inverter horizontally or so that it tilts forward.

(3) When choosing the installation site, ensure there is enough space for heat dissipation. Under normal conditions, the following guidelines should be applied for the space to be kept clear around the inverter:

	Minimum Clearance
Sides	20 cm
Top	20 cm
Underneath	20 cm
Front	5 cm

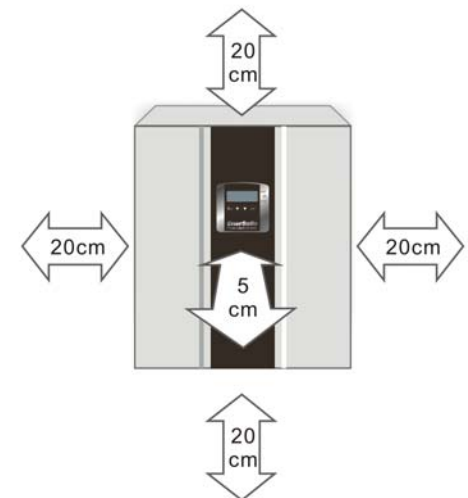

4.3 Mounting the unit

We recommend you to use the supplied wall mounting bracket to mount the Enersolis. For vertical installation and installation on solid concrete or block walls, when selecting the mounting materials, be sure to take into account the weight of the Enersolis.

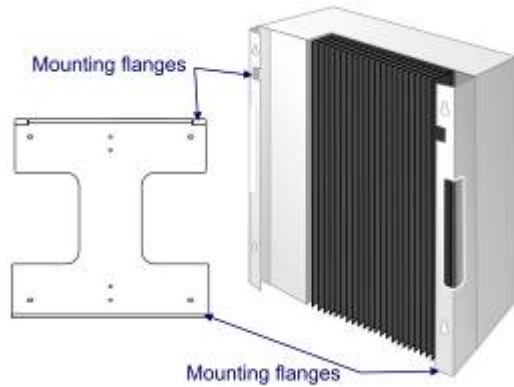

If you do not want to use the supplied wall mounting bracket as a template, observe the dimensions shown in the drawing above. The procedure for mounting the inverter using the wall mounting bracket is described on the following pages.

4.3.1 Installation step

Step1. Fit the wall mounting bracket.

To mark the positions to drill the holes, you can use the wall mounting bracket as a drilling template.



Step2. Now hang the Enersolis onto the wall mounting bracket using its upper mounting plate so that it cannot be moved sideways.

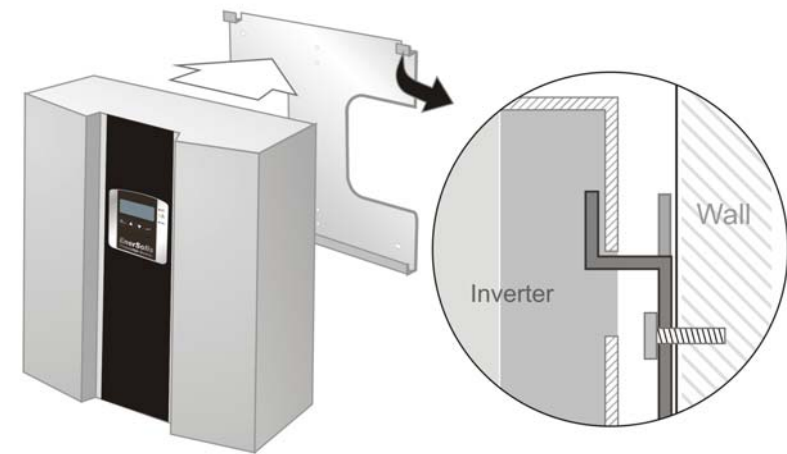

Step3. Make sure that the Enersolis is positioned securely on the bracket.

4.4 Electrical installation

The complete installation for the Enersolis is shown schematically in the following diagram (Fig. 1)

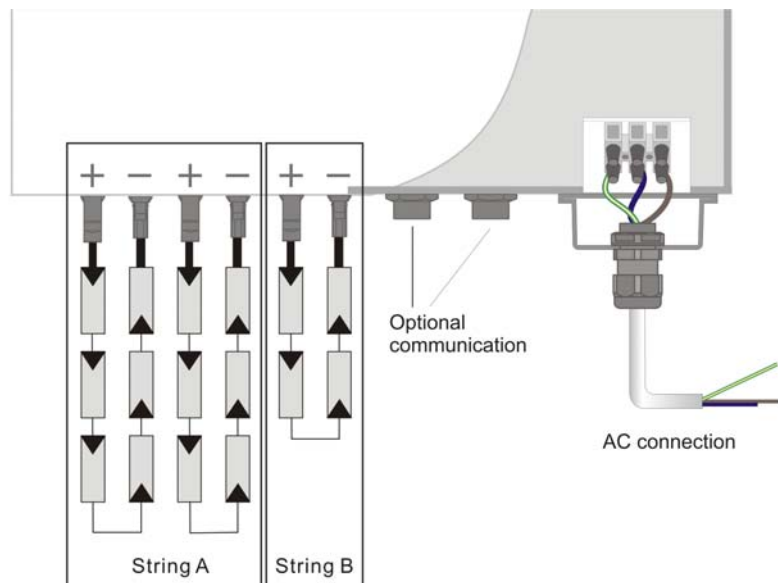

Fig. 1

4.4.1 Connecting to the grid (AC utility)

To connect the AC cable, proceed as follows:

Step 1. Measure grid's (utility's) voltage and frequency.

※The voltage and frequency of Utility are depended on different setting in each country.

Step 2. Before wiring the PV-Inverter, ensure the main breaker in the primary utility breaker box is switched OFF. Switch this breaker ON only after all wiring is completed as instructed in the procedures.

Step 3. Remove the screws that secure the case of the Enersolis and carefully remove the cover. Remove the connection from the cover as shown in Fig. 2.

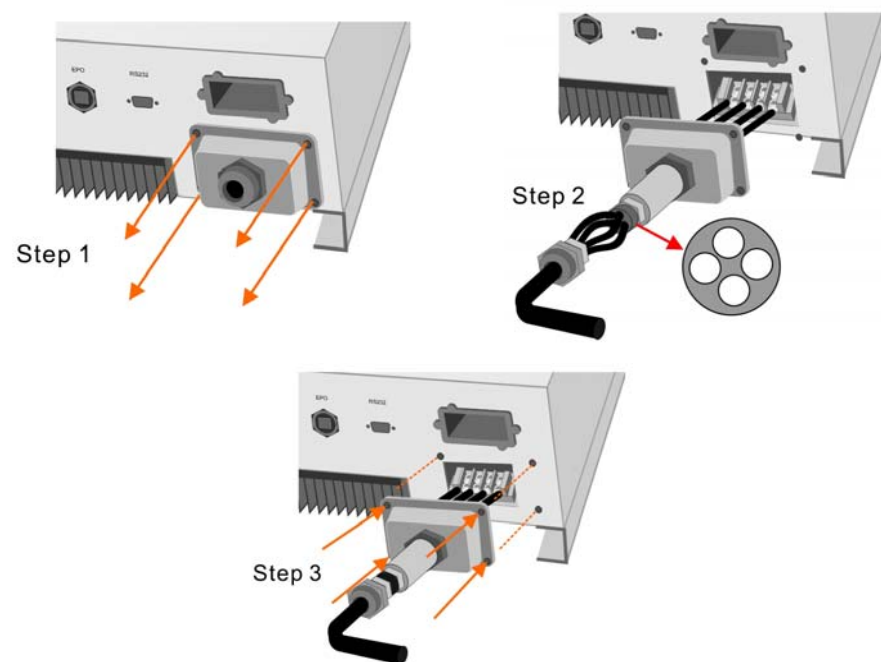

Fig. 2

Step 4. Insert utility wires through cable gland. Connect wires according to polarities indicated on terminal block.

L1 means LINE1 (black), N means Neutral (White), L2 means LINE2 (Red), G means system ground(yellow-green) as shown in Fig. 3

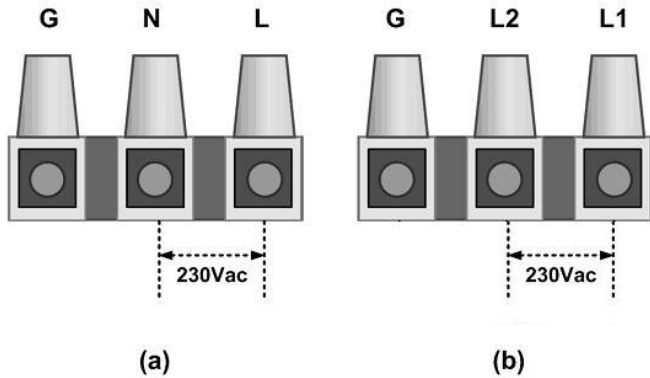

Fig. 3

Step 5. Fix the housing cover of the EnerSolis and evenly tighten the four screws.
 ※To prevent risk off electric shock, ensure the ground wire is properly earthed before operating the PV Inverter.

※Suggested cable width for AC wire

Model	Diameter Φ (mm)	Area (mm ²)	AWG no.
Energolis 4200/5000	>2.59	>5.5	> 10
Energolis 2200/3300	>2.05	>3.5	>12

4.4.2 Connecting the PV Array (DC)

4.4.2.1 PV Module requirements

The Energolis is designed to be connected to two input connector terminal for Energolis 2200/3300/4200/5000. It is must with the same PV module string number to String A and String B for Energolis 2200/3300 but it is allowed with the same or different PV module string number to String A and String B for Energolis 4200/5000.

4.4.2.2 Wiring to PV Module

The Energolis is equipped with PV quick connects for connecting up to two PV strings.

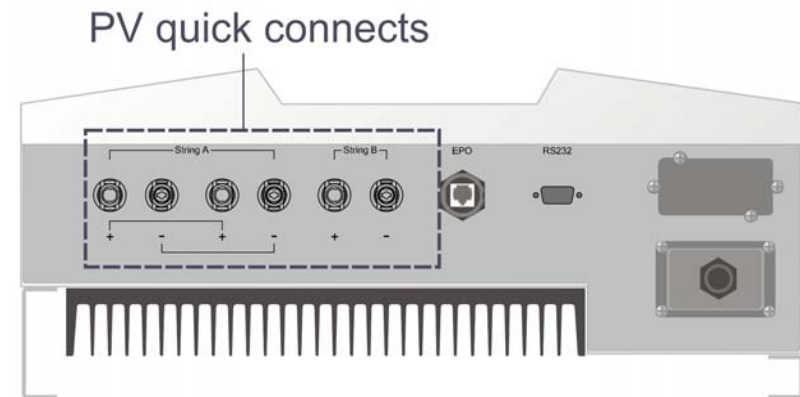

Fig. 4

※The Guidelines for Matching PV Array to the Energolis PV-Inverter Input for determining the number of panels required in the PV string (panels connected in series), you must ensure that the following three requirements are met:

1. To avoid damage to the inverter, make sure the maximum open circuit voltage (Voc) of each PV string is less than 500 Vdc under any condition. Voltage over 500 Vdc will damage the inverter.

2. Do not exceed the maximum array short circuit-current rating marked on the inverter.
3. To achieve maximum energy harvest from your array, ensure that the Vmp (voltage at maximum power) does not drop below 150 Vdc or increase above 450 Vdc under most conditions.

To wire the PV array to the Enersolis Inverter, follow these steps:

- Step 1: Check that the PV generator connectors have the right polarity and do not exceed the maximum string voltage.
- Step 2: Connect the POSITIVE (+) wire from the #1 PV string to PV Inverter positive (+) connect.
- Step 3: Connect the NEGATIVE (-) wire from the #1 PV string to PV Inverter negative (-) connect.
- Step 4: Connect the GND wire from the #1 PV string to PV Inverter GND connect.
- Step 5: If necessary, repeat step 2 and Step 4 for the #2 PV string. Double checks that the wires are in the proper locations.

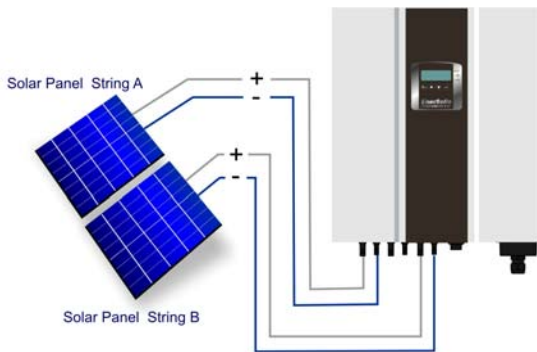









Fig. 5 DC Connections for a Two-String PV Array

5 Front panel Functional Descriptions



Symbols on the LCD Display Panel

① LCD Display	
Symbol	Description
LINE	Utility Source
	Inverter Working in specified mode
	Solar Cell
	Inverter operation mode Flow Chart
	4 Digits Measurement Display

LED Indicators		
②		RED LED steadily lights up to indicate that the Ground fault or DC input isolation fault.
③		YELLOW LED steadily lights up to indicate that the utility (ex. Voltage, frequency etc.) is not matches with the input standard of the inverter.
④		Green LED steadily lights up to indicate that the Solar Cell power is greater than sleep power; the LED flashes flickeringly to indicate that the Solar Cell power is smaller than sleep power.
Control Keypads		
⑤		Special Function Log in /out
⑥		Go to previous page.
⑦		To re-confirm the change of Inverter Setting
⑧		Go to previous page.

6 Starting the inverter

Before the inverter is started, be Ensure as follow:

- The housing cover is securely screwed tight.
- Ensure the AC breaker is OFF.
- Ensure the DC cables (PV strings) are fully connected.
- Ensure the AC (utility) cable is connected correctly.

6.1 Operation Test and Installation Instruction

6.1.1 Connect the PV string voltage by switching on the DC circuit breaker. The Inverter starts automatically when it receives DC voltage greater than $120V_{dc}$. All of the LEDs will light up. The LCD display will illustrate drawing A .

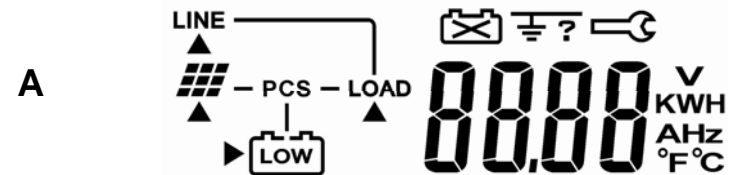

6.1.2 After 3 seconds, the LCD display will illustrate from drawing A to drawing B1 and B2. The Green LED flashes flickeringly to indicate that the DC input power is smaller than sleep power. The yellow LED steadily lights up to indicate that no utility exists.

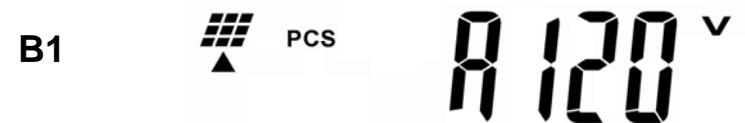

B2



6.1.3 Turn on the AC breaker. If Utility specification (ex. Voltage, frequency etc.) is matched with the specs of the inverter, after 300 seconds the LCD display will illustrate drawing C. And the Yellow LED will go out to indicate that the utility is acceptable by the inverter. If Utility's specification (ex. Voltage, frequency etc.) is not matched with the specs of the inverter then an error code or error status will be shown on the screen.



6.1.4 After 5 seconds, if the DC soft start of the inverter is successful, the LCD display will illustrate drawing D. The Green LED still flashes flickeringly.



6.1.5 After 10 seconds, if the AC soft start of inverter is successful the LCD display will illustrate drawing E.

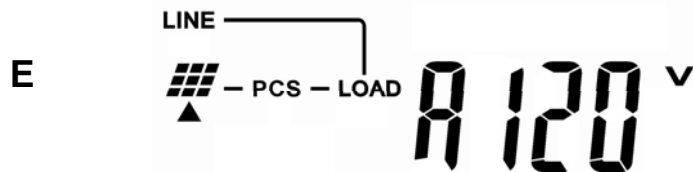

6.1.6 If the inverter is in failure (ex. Output Current Over Range), then an error code or error status will be shown on the screen. (EX. Drawing F)



6.1.7 If start-up operation of the inverter is completely and successful. The LCD display will illustrate drawing E.

6.2 Check Measured Values & Figures detected by INVERTER

If you would like to check the measured values & figures detected by the Inverter, please use scroll up ▲ and scroll down ▼ key pads. When you use scroll down key pad, the LCD display will illustrate as:

6.2.1 Input DC Voltage of String A, as drawing G.



6.2.2 Input DC Voltage of String B, as drawing H.



6.2.3 Input DC Current of String A, as drawing I.



6.2.4 Input DC Current of String B, as drawing J.



6.2.5 Output Power of Booster A, as drawing K.



6.2.6 Output Power of Booster B, as drawing L.



6.2.7 Output Voltage of Inverter (Utility Voltage) , as drawing M.



6.2.8 Output Frequency of Inverter (Utility Frequency) , as drawing N.



6.2.9 Output Current Supplied to Load, as drawing O.



6.2.10 Output Power Supplied to Load, as drawing P.



6.2.11 Energy KWH Supplied to Load, as drawing Q.



6.2.12 INVERTER Inner Temperature (°C, °F) , as drawing R.



6.2.13 Heat sink Temperature (°C, °F), as drawing S.

S



6.3 Inverter status descriptions

The Enersolis starts up automatically when DC-power from the PV panel is sufficient. Once the PV-Inverter starts, it enters into one of the following status:

Operation mode	LCD panel display	Description
Normal		In this mode, the Enersolis works normally. Whenever the supplied power from PV panel is sufficient (500VDC>PV>120VDC), the Enersolis converts power to the grid as generated by the PV panel. In normal mode, the green LED is on to indicate that it feeds power to the grid.
standby		If the power is insufficient, (60VDC<PV<120VDC) the Enersolis enters into a standby mode but attempts to connect to the grid.
Error	 	The internal intelligent controller can continuously monitor and adjust the system status. If the Enersolis finds any unexpected conditions such as grid problems or internal failure, it will display the information on its LCD and light up the red LED.
EPO		Emergency Power Off Mode. In this mode, the Enersolis does not take any power from the grid.
Shutdown		In case of little or no sunlight, The Enersolis automatically stops running. In this mode, the Enersolis does not take any power from the grid. The display and all of the LEDs on the front panel do not work.

7 The communications interface

7.1 Standard communications interface

7.1.1 RS232 interface definition

The RS232 interface shall be set as follows:

Baud Rate	9600 bps
Data Length	8 bits
Stop Bit	1 bit
Parity	None

The Pin Assignments of true RS232 type. The pin assignments of true RS232 type are illustrated as follows:

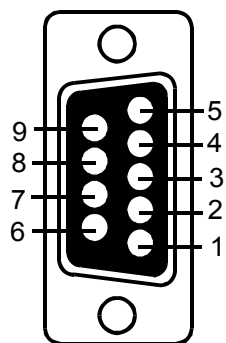

Pin 2: RS232 Rx

Pin 3: RS232 Tx

Pin 5: Ground

7.2 Option communication card

7.2.1 Hardware Installation Procedure

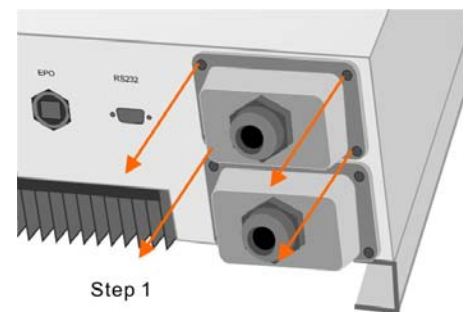

Open the top and sides of the cabinet

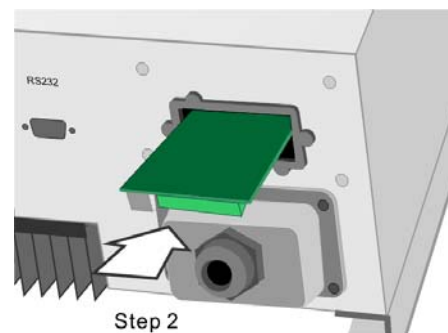

Put the communication card into the slot

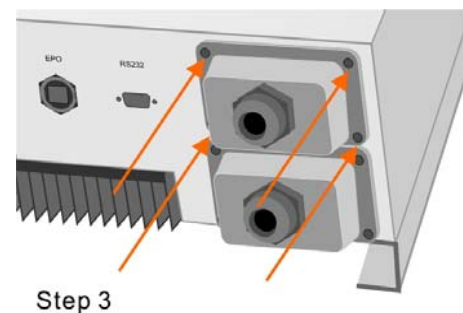

Screw back the side & top cover and complete the installation

7.2.2 RS-485 card

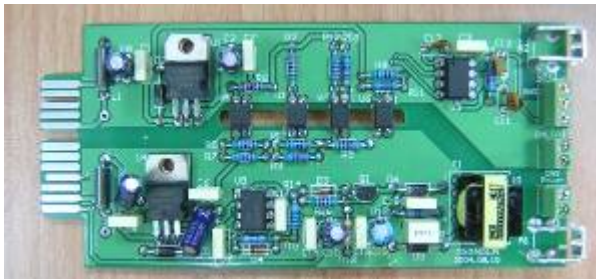

CN1 is for the function of the terminal resistor. Short pin1-2 to enable the function and short pin2-3 to disable it.

CN2 is RS485 terminal

Definition

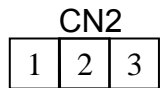

- 1 → Ground
- 2 → A/Data+
- 3 → B/Data-

7.2.3 USB card

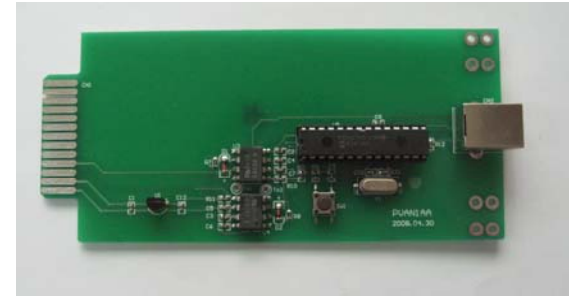

7.2.3.1 CN2 for USB.

7.2.3.2 Definition

7.2.3.3 Comply with USB version 1.0 & 1.5Mbps.

7.2.3.4 Comply with USB HID Version 1.0.

7.2.3.5 The Pin Assignments of the USB card:

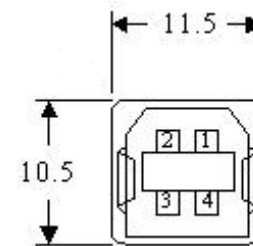

- 1 → VCC (+5V)
- 2 → D-
- 3 → D+
- 4 → Ground

7.2.4 True Relay Contact Board (DCE-B card)

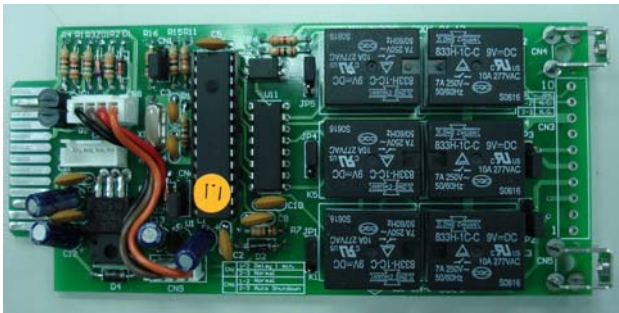

7.2.4.1 The pin assignments of 10-Pin Terminal:

1	2	3	4	5	6	7	8		
---	---	---	---	---	---	---	---	--	--

Pin 1: Voltage of utility is abnormal.

Pin 2: PV strings voltage is normal.

Pin 3: PV strings voltage is abnormal.

Pin 4: Frequency of utility is abnormal.

Pin 5: Anti-islanding.

Pin 6: Output current of inverter is exceeds range.

Pin 7: Temperature of Heat-sink is too high.

Pin 8: Common.

7.2.4.2 The capacity of each relay contact is 40Vdc/25mA.

7.2.4.3 Flexible signal output for N.C.(Normal close) or N.O.(Normal open) contact by shorting pin1-2 or pin2-3 from of JP1-5.

7.2.5 TCP/IP Cards



7.2.5.1 TCP/IP (Ethernet) card

7.2.5.2 For installation, please refer to the user's manual attached with the card.

8 Inverter Status diagnostics and repair

The Enersolis is equipped with a self diagnostic system that automatically identifies a large number of possible operation issues by itself and displays them on the LCD screen. Therefore it is possible to quickly isolate technical issues, and to distinguish between Service Codes related to the installation versus Service Codes which are internal to the inverter. Whenever the self diagnostic system has identified a particular issue, the respective Service Code is displayed on the LCD screen.

Table 2. Inverter error code and error code description

LCD indicate	Designation	Description	Repair	
Er00	DC_BUS pre-Charge fail	The Inverter is in soft start procedure, but the DC Bus can not reach and maintain anticipative charging voltage	<ol style="list-style-type: none"> 1. Disconnect ALL PV (+) or PV (-) 2. Wait for few seconds 3. After the LCD switches off, reconnect and check again 4. If error code keeps recurring, contact your local distributor 	
Er03	INVERTER voltage abnormal	The Inverter Output voltage is abnormal		
Er07	DC_BUS over-voltage	The DC BUS inside is lower or high than expected		
Er08	DC_BUS under-voltage			
Er17	EEPROM ERROR on the control board	EEPROM Data is wrong		
Er19	DC_BUS discharge fail	Capacitors of the DC Bus can't be discharged down		
Er22	Output Relay fail	The Inverter Output Relay is abnormal		
Er24	Output Current sense fail	The Inverter Output Current fails to detect.		
Er25	BOOSTER_A over-current	Over-current on the DC side. This fault code is displayed if the current in the DC network is larger than specified.		
Er26	BOOSTER_B over-current			
Er30	Rating setting of Driver board is not match EEROM of Control board	EEPROM Data is wrong		
Er06	EPO	Inverter enters into EPO mode (Emerge Power Off)		<ol style="list-style-type: none"> 1. Remove the short circuit occurred at the EPO terminal. 2. If error code keeps recurring, contact your local distributor.
Er09	Inverter Output over-current	Over-current on the AC side. This fault code is displayed if the current in the AC network is larger than specified.		<ol style="list-style-type: none"> 1. Turn off AC breaker, then check the peripheral AC system configuration and the grid conditions. 2. If error code keeps recurring, contact your local distributor for help.
Er11	Inverter over-load	Overload on the AC side. This fault code is displayed if the load in the AC network is larger than specified.		
Er13	INVERTER short-circuit	Short-circuit on the AC side.		
Er14	INVERTER PLL fail	The phase of Inverter can't synchronize with the utility.		

Er29	INVERTER output DC current over spec.	The DC component of the electricity fed into the grid is longer than permissible range.	
Er10	Inverter Over temperature	The internal temperature is too high.	<ol style="list-style-type: none"> 1. Try to reduce the ambient temperature. 2. Move the inverter to cooler place. 3. If error code keeps recurring, contact your local distributor for help.
Er18	Heat sink Over temperature	The Hest sink temperature is too high.	

Table 3. Grid fault alarm code and alarm Code Description

LCD indicate	Designation	Description	Repair
AL00	Utility Voltage Over-Voltage	Utility Voltage Greater or Smaller than the permissible value.	<ol style="list-style-type: none"> 1. Wait for 1 minute, if the grid returns to normal, the inverter automatically restarts. 2. Check grid connection, such as wires and connectors. 3. Make sure grid voltage and frequency meet the proper specifications. 4. If error code keeps recurring, contact your local distributor for help.
AL01	Utility Voltage Under-Voltage		
AL02	Utility Voltage Over-Frequency	Utility Frequency Greater or Smaller than the permissible value.	
AL03	Utility Voltage Under-Frequency		
AL04	BOOSTER_A Input Over-Voltage	Over or Under voltage at DC input.	<ol style="list-style-type: none"> 1. Disconnect ALL PV (+) or PV (-). 2. Check the open PV voltage is outside the 120Vdc ~ 500Vdc. 3. If PV voltage is normal and the problem still occurs, contact your local distributor for help.
AL05	BOOSTER_A Input Under-Voltage		
AL06	BOOSTER_B Input Over-Voltage		
AL07	BOOSTER_B Input Under-Voltage		
AL08	Anti-Islanding	No Utility or Utility fail	<ol style="list-style-type: none"> 1. Disconnect ALL PV (+) or PV (-) 2. Check grid connection, such as wires and connectors. 3. Check grid usability. 4. If Utility is normal and the error code keeps recurring, contact your local distributor for help.
AL 13	Phase of Utility is fail		
AL14	Waveform of Utility is fail		
AL09	Inverter Voltage unbalance	Inverter Voltage Waveform is in unbalance	<ol style="list-style-type: none"> 1. Shut down inverter (Unplug PV generator from the input). 2. Check grid usability and Restart inverter (plug PV generator from the input). 3. If error code keeps recurring, contact your local distributor for help.
AL10	GFDI	Leakage current on ground conductor is too high.	<ol style="list-style-type: none"> 1. Unplug PV generator from the input, check AC peripheral system 2. After the problem is cleared, re-plug the PV. Check the PV-Inverter status. 3. If error code keeps recurring, contact your local distributor for help.
AL11	Isolation Fault	The impedance is between PV (+) & PV(-) and Ground is smaller than 1MΩ.	<ol style="list-style-type: none"> 1. Disconnect ALL PV (+) or PV (-). 2. Check the impedance between PV (+) & PV (-) and Ground. The impedance must be larger than 2MΩ. 3. If error code keeps recurring, contact your local distributor for help.

9 Specifications

Model		ES2200	ES3300	ES4200	ES5000
Inverter Technology	Conversion Mode	Sine-wave, Current source, High frequency PWM			
	Isolation Method	Transformer-less Design*			
DC Input Data					
Nominal DC Voltage		360 VDC			
Max. DC input Voltage		500 VDC			
Working range		120VDC~500VDC**			
Max DC input current (Each MPPT Tracker)		14.6 Amp	22 Amp	14 Amp	17.65 Amp
MPPT Range		150 VDC ~ 450 VDC			
MPPT Tracker		1		2	
AC Output Data					
Nominal AC Power		2000	3000	4000	5000
Max. AC Power		2200	3300	4200	5300
Nominal AC Voltage		AC 230V			
Output Connect Method		1-Phase / 2-Wires(L, N, G) or 1-Phase / 3-Wires(L1, L2, G)			
AC Voltage Rang		184~264.5Vac(Base on 230 Vac)			
Nominal AC Current		8.7Amp	13Amp	17.4Amp	21.7Amp
Frequency		50/60Hz Auto-Selection (47.5 ~ 50.2 Hz or 59.3 ~ 60.5 Hz)			
Power Factor		>0.99 with nominal AC current			
Current Distortion		Total Harmonic current : Less than 5% Single Harmonic current : Less than 3%			
Efficiency Data					
Max. efficiency		>96%			
Euro efficiency		>94%			
CEC efficiency		>94%			
Environmental					
Operating Temperature		-25 °C ~ +50 °C -13 °F ~ 122 °F			
Humidity		0 to 90%(Without condensation)			
Altitude		0 ~ 2000 M / 0 ~ 6600 ft			
Mechanical					
Dimensions (H x W x D in mm / inch)		455 x 430 x 170 / 18 x 17 x 6.7		455 x 510 x 170 / 18 x 20 x 6.7	
Weight (Kgs / Lbs)		20 / 44		25 / 55	
Protection Class		IP65, outdoor			
Cooling		Free Convection			
AC Connector		Terminal			

DC Connector	Multi-Contact	
Communication		
Communication Interface	Standard	RS232
	Optional	USB, RS485, Dry contact, TCP/IP
Front Panel		
LCD	Boost input Voltage/Boost input Current/Boost input Power/AC output Voltage /AC output frequency/AC output current /AC output power/AC Energy yield/Inner Temperature/Heat sink Temperature /Status message/ Error message	
LED	RED	Leakage current fault or DC input isolation fault
	Yellow	Spec. of Utility is not matches with the Utility specifications of the inverter
	Green	Solar Cell power is greater or smaller than sleep power
Key Pad	UP key/ Down key/ Function key/ Enter key	
Protection		
Utility	Over/under Voltage, Over/under Frequency, Ground fault, DC Isolation fault	
Islanding operation detection	Passive : Voltage phase jump detection Active : Reactive power control	
Over Temperature	reduced output power	
Certification		
Safety	Europe	VDE0126-1-1, EN50178, IEC60146-1
	North American	UL1741, IEEE1547
EMI/EMC	EN 61000-6-1, EN 61000-6-3, EN 61000-3-3	

* If the isolation is necessary, option one extra transformer.

** The rated range should be 150V_{DC}-500V_{DC} in order to get the rated output.